

# 2-D Torch Cutting WallWalker®

## Background

Pentek has developed a line of 2- and 3-dimensional working robots to bring fully computerized work capability to nuclear D&D and other hazardous working environments. Introduced in 1996 as wall servicing robots, and generally traded under the name WallWalker®, these machines can be equipped with a variety of work modules, including high-pressure blast nozzles, sluicing nozzles, concrete scabblers, paint heads, inspection cameras, radiation survey devices and other instruments. This new locomotion concept holds the potential to vastly increase work capacity, enhance worker safety, eliminate exposures to hazardous materials, and to function reliably in hostile environments.

## Technology Description

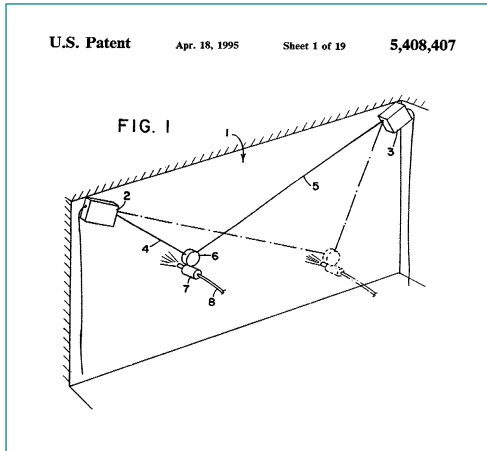

As may be seen in the figure to the left (←), classical WallWalker locomotion utilizes two high strength steel cables strategically placed at high points above the vertical wall to be traversed. Each cable is connected to a load attached at a common point of intersection; this is commonly referred to as the 'work point'. The length of each cable is precisely controlled by a computer-controller which directs the motion of independent motor driver/cable managers located at the point of attachment to the structure. The exact location of the work point is always known with great accuracy, since a) the position of each motor driver/cable manager is always known by virtue of their advanced pre-positioning, and b) the lengths of each of the cables is known by virtue of constant computer monitoring of the length of cable each motor driver/cable manager pays out and retrieves. Mathematically, the system is a linear arrangement of straight lines which continually form and re-form the boundaries of a triangle as the work point is moved over the

locus of points which define any arbitrary path. The cables are kept taut by the gravitational forces which act on the load and transmit it to the supports through the cables. Rated load carrying capacity of the system is over 200 kg.

## Application of WallWalker® to Precision Torch Cutting of Heavy Steel Structures

Application of WallWalker to tall and long surfaces is straightforward. For example, the demands of performing work on the large steel panels which comprise the hull surface offer a clear opportunity to exploit WallWalker automation; i.e., access is difficult and operations are repetitive.

← As this close-up view readily shows, temporary



supports for the two motor drivers/cable managers can be installed above the target area to define the operational boundaries. In this particular application, both supports were mechanically attached to the steel hull using temporary spot-welds; they could have been attached via small clips mounted to the toe rail on the deck of the ship. Use of temporary scaffolding and suspended baskets as a platform for skilled workers is eliminated. .



### Contact

### Information

Mr. Brad Fuller

Pentek, Inc.

1026 Fourth Avenue

Coraopolis, Pennsylvania

15108 USA

+1 412-262-0725 **Phone**

+1 412-262-0731 **FAX**

pentekusa@aol.com **E-mail**

www.pentekusa.com **Web**

# 2-D Torch Cutting WallWalker®

The precision of WallWalker's path control allows the work point to be programmed to follow the contour of the weld seams or other cut lines without breaks for fatigue, need for good lighting or concern for inclement weather. The size of the area which can be serviced is virtually limitless, as the motor drivers/cable managers are designed as once-through devices which pass the cable through the reeving mechanism only once, while allowing the free end of the cable to spool out without need of a traditional cable drum. Hence, the dimensions of motion are virtually unlimited.

## Torch Cutting Details

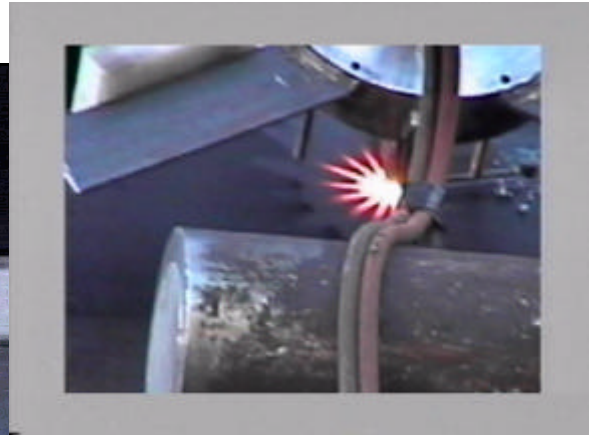
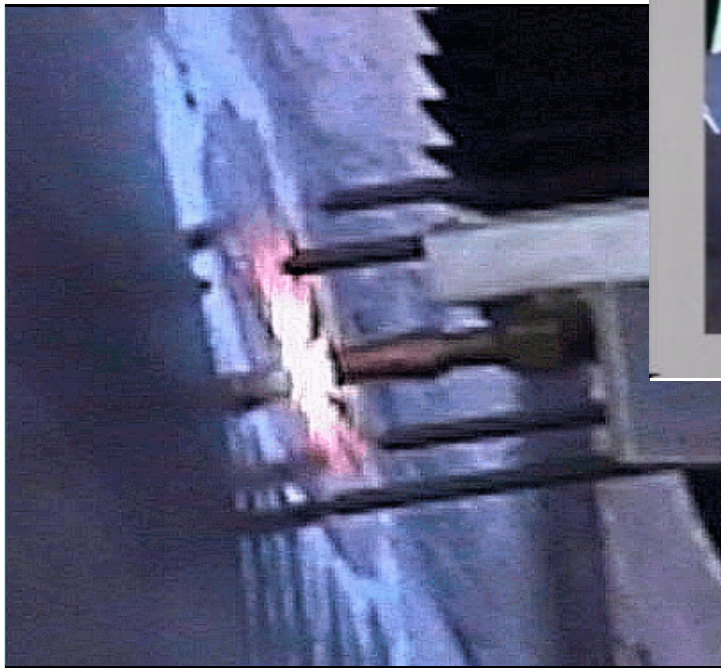

Design of WallWalker's tool carrier allows it to be readily adapted to well established, conventional processes which have been demonstrated to effectively and economically produce the desired result. The cutting torch used here is a propane fueled system commonly found in shipyards and fabricating plants; oxyacetylene or gasoline torches could be accommodated with similar ease.

Activation sequencing requires that the torch be initiated, held stationary until burn through is achieved, and then moved in accordance with the desired path at the most effective cutting speed for the metal conditions. **The 1-inch thick steel plate cut during this particular demonstration was burned at a rate of 9-inches/minute along the path directed by WallWalker's computer controller;** of course, faster or slower speeds could be achieved depending on the specific process conditions, as WallWalker will follow any path at variable speeds up to 60 feet/minute. The stability of WallWalker's motion provided a smooth cutting motion and a controlled standoff distance between the tip of the torch and the surface of the ship. An exceptionally clean cut was achieved, comparable to that expected on a stationary fabrication table; and no post-cut grinding was required. Upon completion of the closed path, the cut piece simply 'dropped out.'

This shipyard demonstration reveals yet another dimension of the versatility of WallWalker technology. It points to the practicality and feasibility of bringing fabrication plant cutting, welding, and machining precision directly to the working surface of a large structure. WallWalker provides the opportunity to *bring the factory to the ship*, wherein significant savings in fabrication and repair costs may accrue. This concept may be further extended to direct programming and execution of field work based on AutoCAD or similar design/manufacturing programs which are compatible with WallWalker's state-of-the-art Windows 95/98 operating system.

Future applications of this technology to D&D operations include reactor dismantlement, large component size reduction and facilitation of access in structures where risk of unacceptable personnel exposure is significant.